

ARTICULO: 2225
Válvula de Aguja extremos roscados
Threaded ends Needle valve

Características	Features
<ol style="list-style-type: none"> 1. Válvula de Aguja. 2. Construcción en acero inox. ASTM A479 (grado 316). 3. Extremos roscados hembra s/ ISO 228/1. 4. Presión máxima de trabajo 6000 psi a 38°C. 5. Temperatura de trabajo – 54 a 232 °C. 6. Dispositivo de seguridad del bonete para evitar desajuste. 7. Diseño del obturador con cierre posterior para proteger la estopada con válvula totalmente abierta 	<ol style="list-style-type: none"> 1. Needle valve. 2. Made of Stainless steel ASTM A479 (grade 316). 3. Threaded ends female acc. to ISO 228/1. 4. Max. Working pressure 6000 psi at 38°C. 5. Working Temperature – 54 to 232 °C. 6. Safety bonnet lock prevents accidental loosening. 7. Back seating design protects the packing in fully open position.

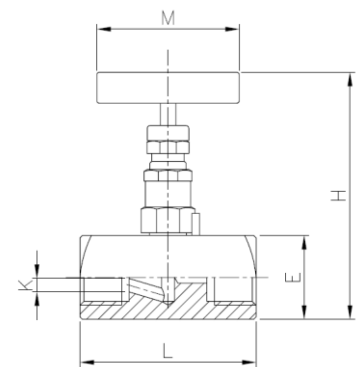
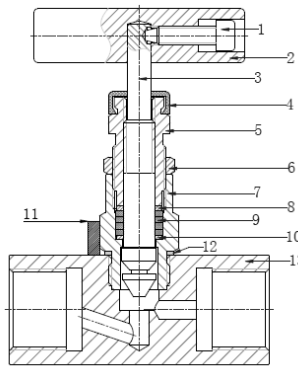

Nº	Denominación / Name	Material	Acabado Superficial / Surface Treatment
1	Tornillo de Fijación maneta / Grib Screw Handle	Acero Inoxidable 201 / S.S. 201	-----
2	Maneta / Handle	Acero Inoxidable / S.S. ASTM A479 Gr.316	-----
3	Eje Obturador / Stem Shaft	Acero Inoxidable / S.S. ASTM A479 Gr.316	Nitrurado Gaseoso / Nitrogen Treatment
4	Tapón protector / Dust Cap	Plastic	-----
5	Prensaestopas / Packing nut	Acero Inoxidable / S.S. ASTM A479 Gr.316	-----
6	Tuerca prensaestopas / Lock Nut	Acero Inoxidable / S.S. ASTM A479 Gr.316	-----
7	Bonete / Bonnet	Acero Inoxidable / S.S. ASTM A479 Gr.316	-----
8	Arandela / Washer	Acero Inoxidable / S.S. ASTM A479 Gr.316	-----
9	Estopada / Stem packing	PTFE + Grafito / PTFE + Graphite	-----
10	Arandela / Washer	Acero Inoxidable / S.S. ASTM A479 Gr.316	-----
11	Perno Fijación / Lock Pin	Acero Inoxidable 304 / S.S. 304	-----
12	O'ring	FKM	-----
13	Cuerpo / Body	Acero Inoxidable / S.S. ASTM A479 Gr.316	

DIMENSIONES GENERALES / GENERAL DIMENSIONS

Ref	Medida / Size	PN (psi)	Dimensiones/Dimensions (mm)					PESO / WEIGHT (Kg)
			E	H	L	M	K	
2225 02	1/4"	6000	25.5	90	61	55	4	0,365
2225 03	3/8"	6000	25.5	90	61	55	4	0,355
2225 04	1/2"	6000	28.5	92	68	55	5	0,440
2225 05	3/4"	6000	38	98	76	55	6	0,800
2225 06	1"	6000	44.5	108	85	55	8	1,120

DIAGRAMA DE PÉRDIDAS DE CARGA / HEAD LOSSES DIAGRAM

(H₂O / 20 °C Flujo Horizontal / Horizontal flow).

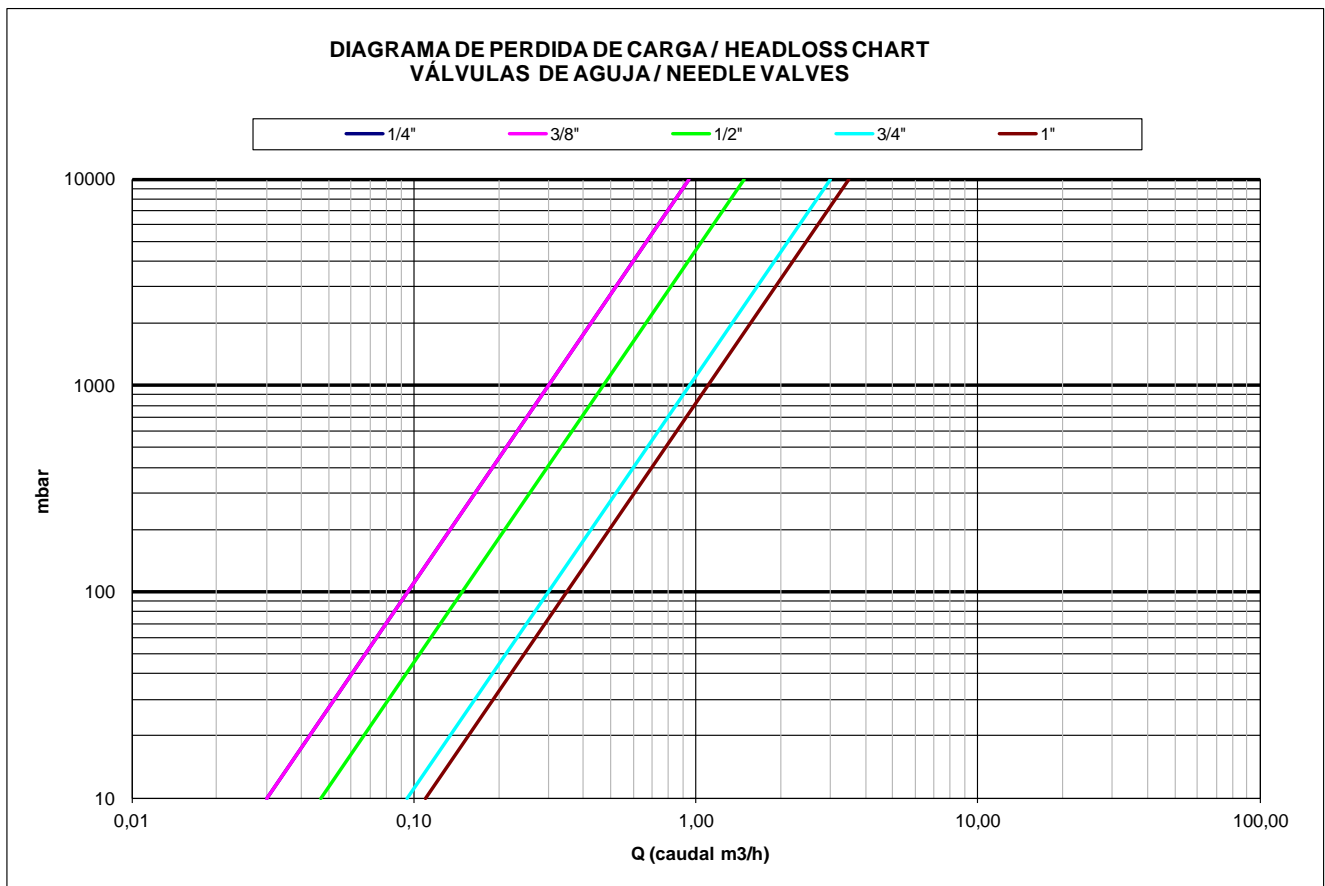

VALORES DE Kv / Kv VALUES

Kv = Es la cantidad de metros cúbicos por hora (m³/h) que pasará a través de la válvula generando una pérdida de carga de 1 bar.

Kv = Flow rate of water in cubic meter per hour (m³/h) that will generate a pressure drop of 1 bar across the valve.

Medida / Size	1/4"	3/8"	1/2"	3/4"	1"
m ³ /h	0.30	0.30	0.63	0.73	1.40

CURVA PRESIÓN TEMPERATURA / PRESSURE TEMPERATURE RATING

