



MWN/JS-S IP68/IP65

Coupled water meter

DN50, DN65; DN80; DN100; DN150

IP68 / IP65 coupled water meter

MWN/JS-S is a dry water meter unit comprising a master water meter, type MWN Nubis, a side water meter, type JS Smart series, and a switchover valve. The design of the coupled water meter features exceptional measurement accuracy at low water flow rates and a modern design. The spring-action switchover valve with its extremely well engineered design automatically switches the operation between the master and the side water meter without any intervention, based on the flow rate. The water meter is compatible with clip-on optical and induction communication modules or reed relay pulse transmitters for remote meter reading. The water meter is designed and manufactured in compliance with the MID Directive, pursuant to EN 14154, ISO 4064, and OIML R49, and can be provided with an IP65 or IP68. The design is classed as operating in the maximum measurement range of R4000.

Application

Coupled water meters are used for the measurement of cold water consumption, up to 50°C with wide flow rate fluctuations (from minimum to maximum values), MOP 16 bar (PN16). This product is recommended for installation in industrial settings, commercial buildings and public facilities (like hospitals, schools and hotels) with a high fire risk, with fire standpipe connections and where high water consumption is possible periodically (for processing) or in an emergency. For installation in horizontal piping with the counter facing upward (H \uparrow). The rotary counters provide indications that are easily readable directly from the front face, meaning the water meters work well in different installation locations. The standard coupled water meters feature counters (IP65) which are compatible with optical and induction communication modules. The standard IP68 coupled water meters with an #UTIP interface (Universal TI Plug – for MWN master meters and JS16 side meters) are compatible with induction communication modules; the modules are installed in the JS4 side meters using an adapter ring.



MWN/JS-S IP68

Robust counter safety cover for protection against external impacts in the water meter's working environment

The product is compatible with universal induction communication modules by supporting #UTIP

The data transmission system is immune to interference from external electromagnetic fields; the EM field immunity is provided by induction detection of counter readings

The water meter identification data can be easily read from the counter cover even with a remote reading module installed

The master water meter counter is IP68 rated

The side water meter counter is TI/IR, IP68 rated

The main spring-action switchover valve passes the water flow from the side/single-jet water meter to the master/impeller water meter or vice versa, depending on the actual flow rate

Auxiliary spring-action valve

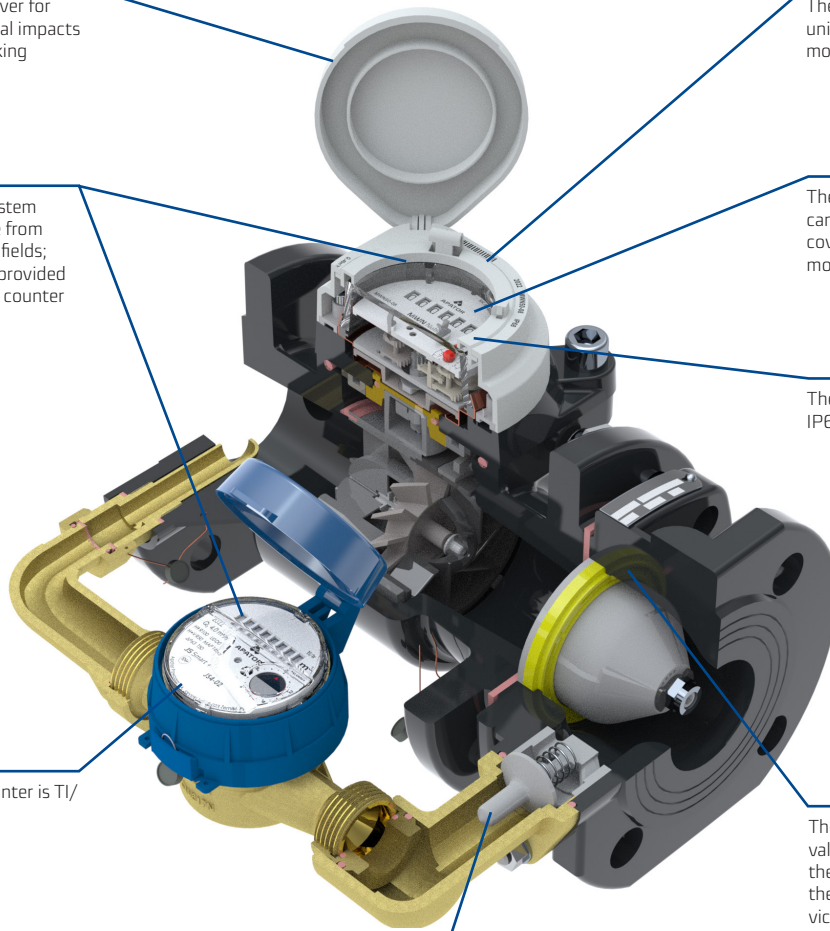

MWN/JS-S IP65

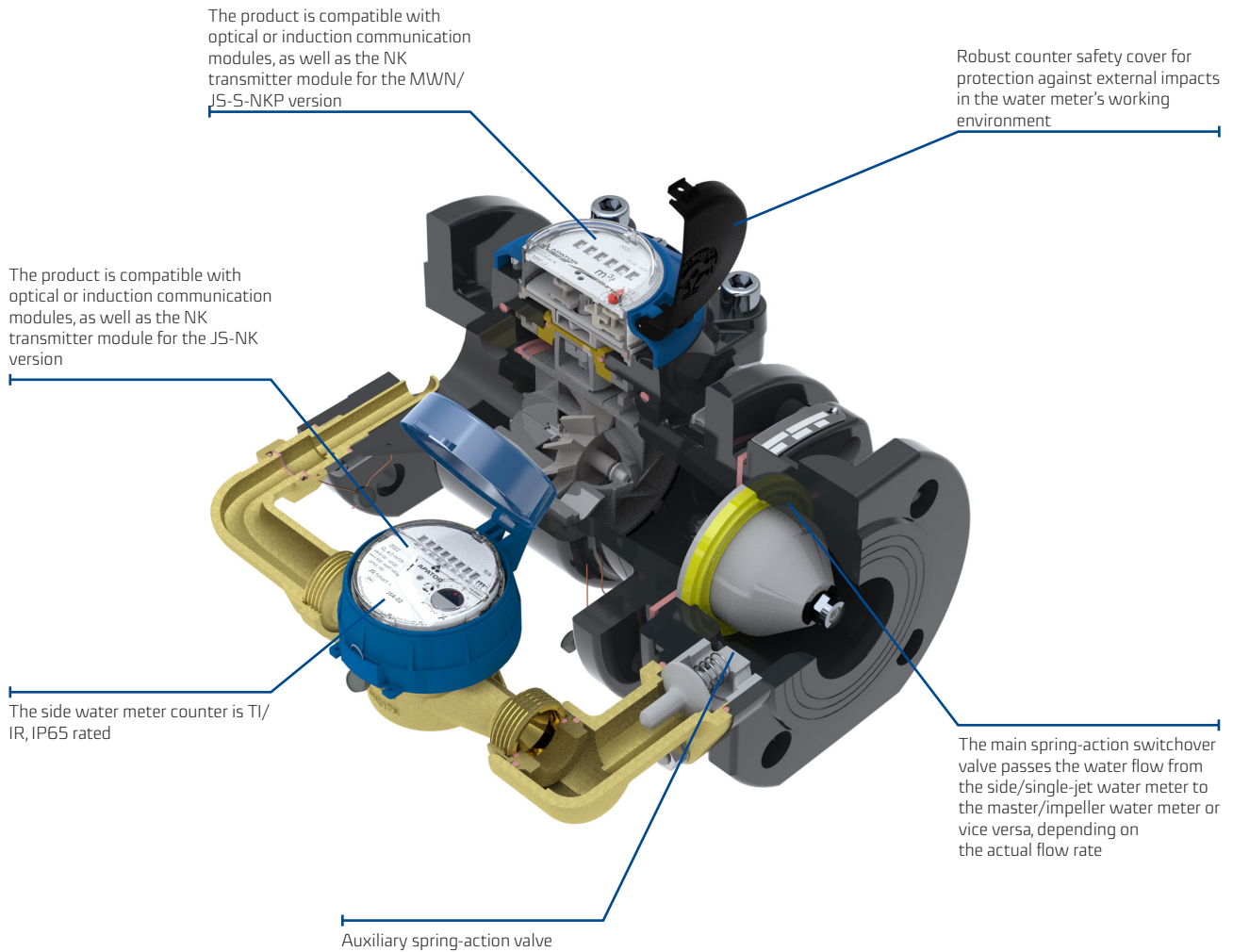

Advantages

Economy:

- Extremely wide measurement range, up to R4000 – H \uparrow
- The measurement starts from the minimum flow rate Q1 of the side water meter and ends with the permanent flow rate Q3 of the master water meter
- Low starting flow
- Remote meter reading via wired or wireless interfaces
- EN ISO 4064 compliant resistance to external magnetic fields
- High anti-corrosive and damage resistance performance of the paint coat (an epoxy powder coating)

Convenience of use:

- The spring-action switchover valve passes the water flow through the side water meter or the master water meter depending on the actual flow rate, both while it is increasing and decreasing
- The counter mechanisms are compatible with remote optical or inductive reading systems (over RF, via pulse signalling, M-Bus or GSM)



- Easy reading of indications and parameters by:
 - Hermetically sealed, non-fogging counter in the IP68 version,
 - Location of the water meter parameter legend:
 - on the counter cover top in the IP68 master water meter version,
 - on the counter cover label in the NK side water meter version.
- Alarm output capability – the meter features a clip-on communication module, capable of remote indication of or any removal of or damage to the module, disruption of operation, reverse flow, leakage, and more
- Remote wired reading transmission capability using the NK transmitters for the MWN/JS-NKP (IP65) version

Reliability

- Tested and robust design
- High operational durability
- The counter mechanisms are protected against mechanical damage

Key features

- Coupled water meter components:
 - master water meter: type MWN, dry, horizontal rotor axis propeller with removable measuring insert,
 - side water meter: type JS, dry, single-jet vane-wheel,
 - spring-action switchover valve operates automatically and requires no external source of power to work.
- For installation in horizontal piping
- The standard side water meter is installed on the right-hand side of the master water meter, looking down the arrows shown on the body; a left-hand side installation is available on request
- Modular design
- Additional counter covers
- Magnetic coupling linking the measurement unit and the counter

Regulatory and standard compliance

- Directive 2014/32/EC of the European Parliament and of the Council of 26 February 2014 on the harmonisation of the laws of the Member States relating to the making available on the market of measuring instruments
- Polish Act of 13/04/2016 on conformity assessment and market control systems
- EN ISO 4064-1÷5:2017-07(E) – Water meters for cold potable water and hot water
- OIML R49:2013 – Water meters for cold potable water and hot water
- EC type test certificate for cold water
- Classification of climate and environmental requirements: Class B (EN-ISO 4064-1:2017 (E))
- Classification of mechanical environmental conditions: Class M1, per Directive 2014/32/EU of the European Parliament and of the Council of 26 February 2014
- Classification of electromagnetic environment conditions: Class E1, E2, as per the Polish Regulation of the Minister of Development of 02/06/2016 and Directive 2014/32/EU of the European Parliament and of the Council of 26 February 2014
- PZH National Institute of Hygiene certificate (all materials used in the coupled water and its spring-action switchover valve have Hygiene Certificates for use with potable water)

Table 1. Specifications – IP65 coupled water meter version with type JS Smart+ / JS Master+ / JS-NK side water meter; R100

Specification			MWN/JS (IP65)				
			MWN/JS 50/4,0-S	MWN/JS 65/4,0-S	MWN/JS 80/4,0-S	MWN/JS 100/4,0-S	MWN/JS 150/16-S
			MWN/JS 50/4,0-NKP	MWN/JS 65/4,0 NKP	MWN/JS 80/4,0 NKP	MWN/JS 100/4,0 NKP	MWN/JS 150/4,0 NKP
Diameter of the main/side water meter	DN	mm	50/20	65/20	80/20	100/20	150/40
Permanent flow rate	Q_3	m ³ /h	25	40	63	100	250
Overload flow rate	Q_4	m ³ /h	31.25	50	78.75	125	312.5
Transitional flow rate	Q_2	m ³ /h	0.064	0.064	0.064	0.064	0.256
Minimum flow rate	Q_1	m ³ /h	0.04	0.04	0.04	0.04	0.16
Starting flow	–	m ³ /h	0.015	0.015	0.015	0.015	0.06
Valve switchover with decreasing flow	Q_{x1}	m ³ /h	1.1	1.3	1.5	1.6	4.5
Valve switchover with increasing flow	Q_{x2}	m ³ /h	2.5	2.8	2.7	2.8	8.5
Measurement range, R	Q_3/Q_1	-	630	1000	1600	2500	1600
Coefficient	Q_2/Q_1	–	1.6				
Temperature class (rated operating temperature)	–	–	T30 (0.1-30°C), T50 (0.1-50°C)				
Flow profile sensitivity class	–	–	U0, D0				
Indicating range	–	m ³	10 ⁶ / 10 ⁵				10 ⁷ / 10 ⁵
Resolution of reading	–	m ³	0.0005 / 0.00005				0.005 / 0.0005
Water pressure class	–	–	MAP16				
Maximum pressure loss	ΔP	kPa	$\Delta 63 = (0.63 \text{ bar})$				
Operating orientation	–	–	H				
Maximum permissible error range: $Q_2 \leq Q \leq Q_4$	ϵ	%	± 2 for $0.1^\circ\text{C} \leq T \leq 30^\circ\text{C}$ cold water ± 3 $T > 30^\circ\text{C}$ water				
Maximum permissible error range: $Q_1 \leq Q < Q_2$	ϵ	%	± 5				
NK reed relay pulse transmitter	Master water meter	dm ³ /pulse	100 (std. pulse rate) / 10				1000/100
	Side water meter	dm ³ /pulse	10 (std. pulse rate) / 0.25; 1; 2.5; 25; 100; 250; 1000				1000/100
Dimensions	L	mm	270 300*	300	300 350*	360 350*	500±1.5
	H (IP65/68)	mm	180/186.5	190/197.5	212/218	222/228	350
	H1 (IP65/68)	mm	190/194.5	200/205.5	222/226	232/236	360
	H2 (IP65/68)	mm	243/271.5	254/282.5	274.5/303	284.5/313	406/434
	h	mm	72	83	95	105	135
	S	mm	280	300	310	340	445
	b	mm	95	104	110	125	150
Side water meter installation	Standard version	Right-hand (looking in the direction of flow)					
	On request	left-hand (looking in the direction of flow)					
Weight	MWN/JS	mm	17.5/19.4	21.0	25.0/27.7	30.0/30.0	75.0
	MWN/JS-NKP	kg	18.0/19.9	21.5	25.5/28.2	30.5/30.5	75.5

* Available as a custom order

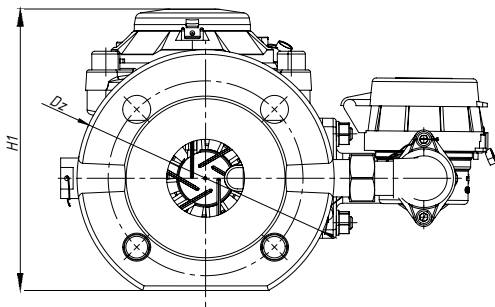
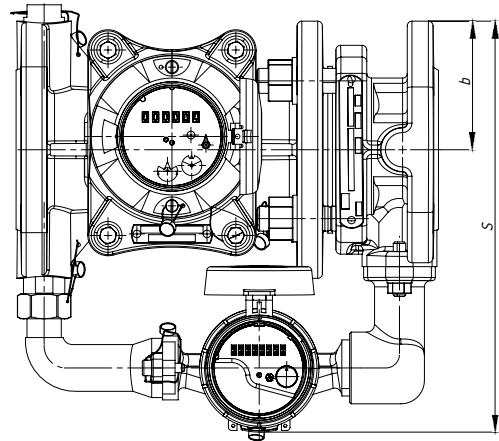
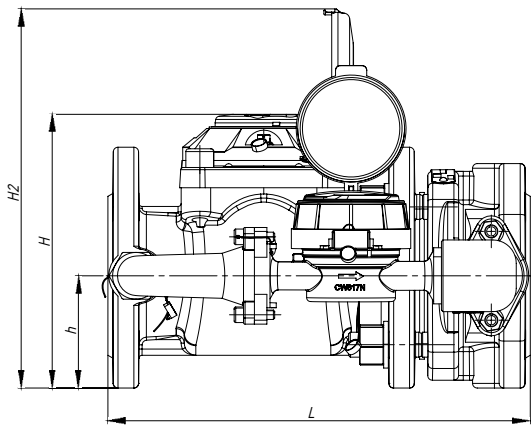

Table 2. Specifications – IP68 coupled water meter version with type JS Smart C+ / JS Master C+ side water meter; R160

Specification			MWN/JS (IP68)				
			MWN/JS 50/4,0-S	MWN/JS 65/4,0-S	MWN/JS 80/4,0-S	MWN/JS 100/4,0-S	MWN/JS 150/16-S
Diameter of the main/side water meter	DN	mm	50/20	65/20	80/20	100/20	150/40
Permanent flow rate	Q_3	m ³ /h	25	40	63	100	250
Overload flow rate	Q_4	m ³ /h	31.25	50	78.75	125	312.5
Transitional flow rate	Q_2	m ³ /h	0.04	0.04	0.04	0.04	0.16
Minimum flow rate	Q_1	m ³ /h	0.025	0.025	0.025	0.025	0.1
Starting flow	–	m ³ /h	0.01	0.01	0.01	0.01	0.04
Valve switchover with decreasing flow	Q_{x1}	m ³ /h	1.1	1.3	1.5	1.6	4.5
Valve switchover with increasing flow	Q_{x2}	m ³ /h	2.5	2.8	2.7	2.8	8.5
Measurement range, R	Q_3/Q_1	-	1000	1600	2500	4000	2500
Coefficient	Q_2/Q_1	–	1.6				
Temperature class (rated operating temperature)	–	–	T30 (0.1-30°C), T50 (0.1-50°C)				
Flow profile sensitivity class	–	–	U0, D0				
Indicating range	–	m ³	10 ⁶ / 10 ⁵				10 ⁷ / 10 ⁵
Resolution of reading	–	m ³	0.0005 / 0.00005				0.005 / 0.0005
Water pressure class	–	–	MAP 16				
Maximum pressure loss	ΔP	kPa	$\Delta 63 = (0.63 \text{ bar})$				
Operating orientation	–	–	H				
Maximum permissible error range: $Q_2 \leq Q \leq Q_4$	ϵ	%	± 2 for $0.1^\circ\text{C} \leq T \leq 30^\circ\text{C}$ cold water ± 3 T > 30°C water				
Maximum permissible error range: $Q_1 \leq Q < Q_2$	ϵ	%	± 5				
Dimensions	L	mm	270 300*	300	300 350*	360 350*	500±1.5
	H (IP68)	mm	186.5	197.5	218	228	350
	H1 (IP68)	mm	194.5	205.5	226	236	360
	H2 (IP68)	mm	271.5	282.5	303	313	434
	h	mm	72	83	95	105	135
	S	mm	280	300	310	340	445
	b	mm	95	104	110	125	150
Side water meter installation	Standard version		Right-hand (looking in the direction of flow)				
	On request		left-hand (looking in the direction of flow)				
Weight	MWN/JS	kg	17.5/19.4	21.0	25.0/27.7	30.0/30.0	75.0

* Available as a custom order

MWN/JS -S IP65 version



MWN/JS -S - NKP IP65 version

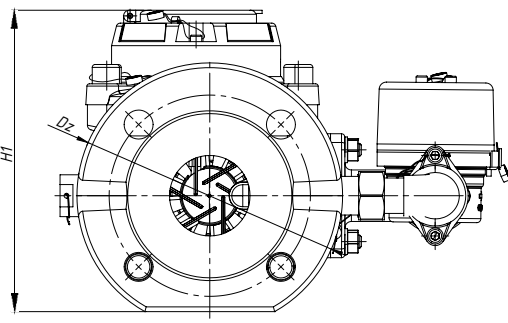
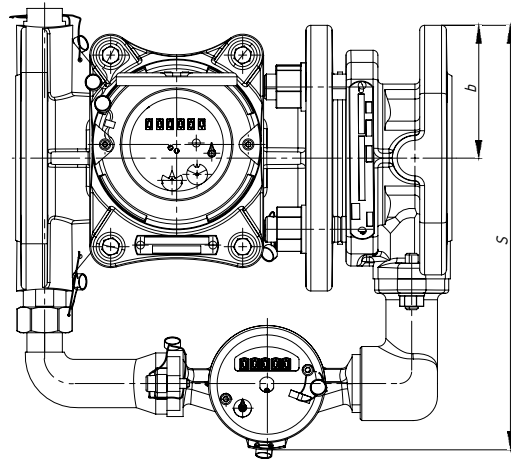
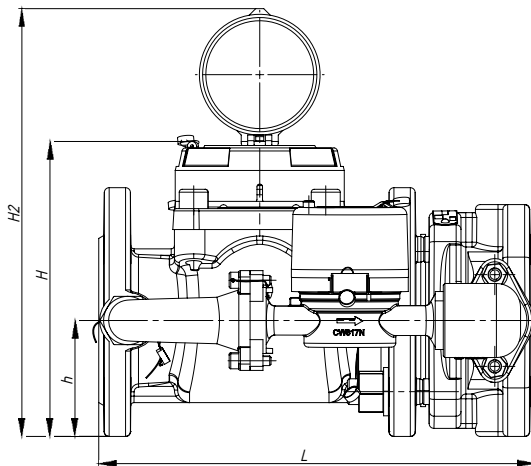



MWN/JS -S IP68 version

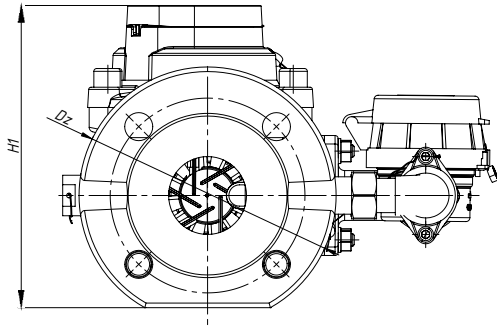
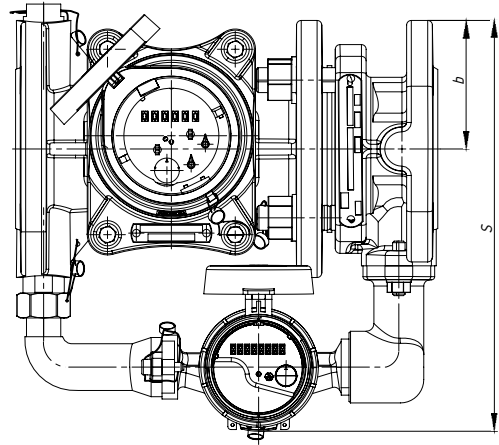
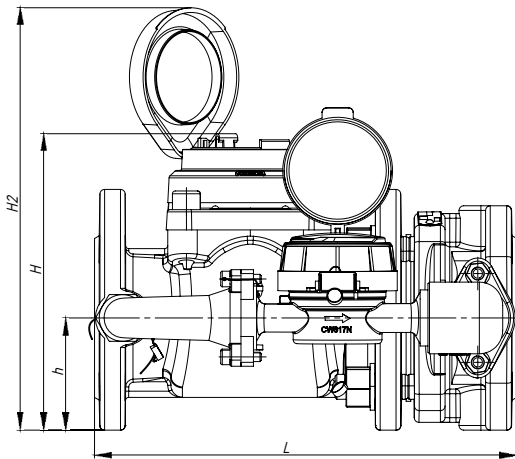

Examples of MWN/JS-S (IP68) water meter compatibility with communication modules:

IN-GSM modules for MWN/JS-S (IP68)

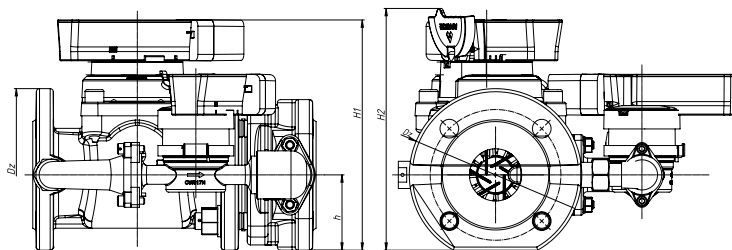
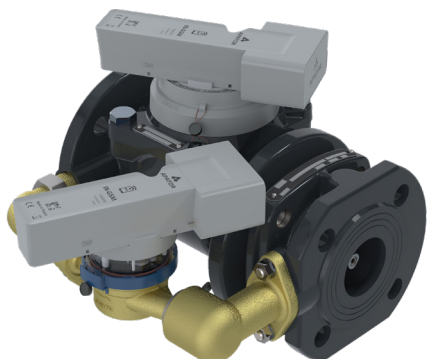

DN		50	65	80	100	150
H1	mm	220.5	231.5	252	262	384
H2	mm	224.5	231.5	256	266	388
h	mm	72	83	95	105	135
Dz	mm	165	185	200	220	285

IN-WMBUS modules for MWN/JS-S (IP68)

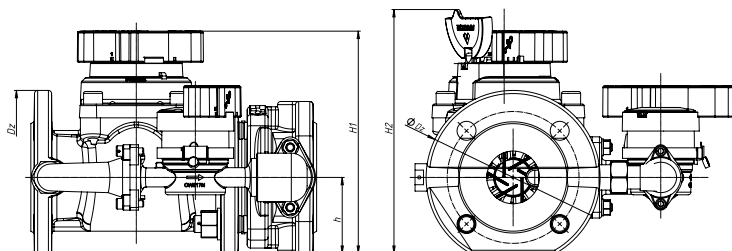
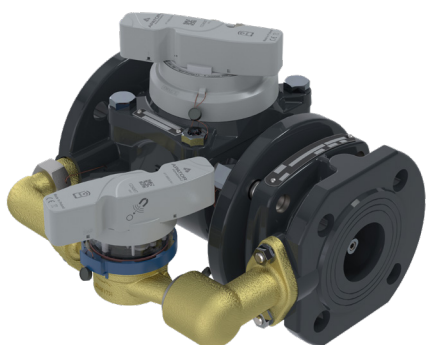

DN		50	65	80	100	150
H1	mm	211.1	222.1	242.6	252.6	374.6
H2	mm	232.1	243.1	263.1	273.6	395.6
h	mm	72	83	95	105	135
Dz	mm	165	185	200	220	385

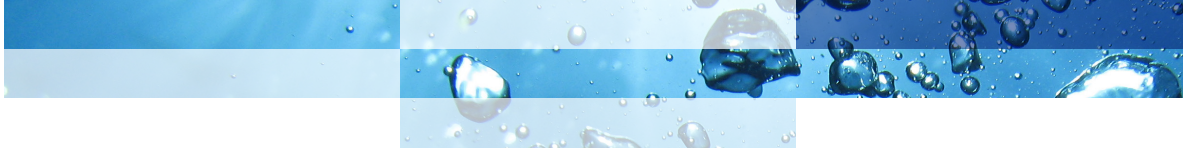

Examples of MWN/JS-S (IP65) water meter compatibility with communication modules:

IN-GSM modules for MWN/JS-S (IP65)

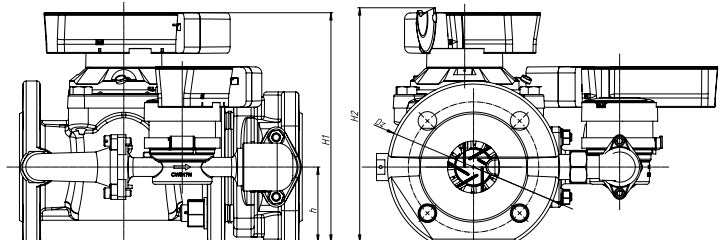
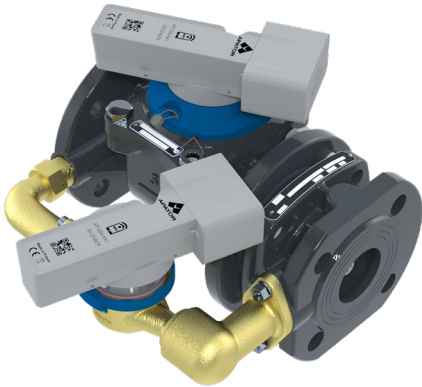

DN		50	65	80	100	150
H1	mm	220	231	251.5	261.5	383.5
H2	mm	224.9	235.9	256.4	266.4	388.4
h	mm	72	83	95	105	135
Dz	mm	165	185	200	220	285

IN-WMBUS modules for MWN/JS-S (IP65)

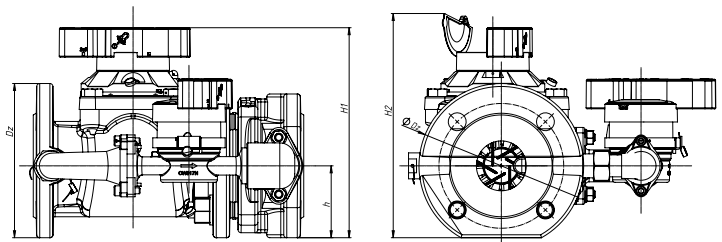

DN		50	65	80	100	150
H1	mm	210.8	221.8	242.3	252.3	374.3
H2	mm	224.9	235.9	256.4	266.4	388.4
h	mm	72	83	95	105	135
Dz	mm	165	185	200	220	285

IP65-rated water meter with the NK transmitter

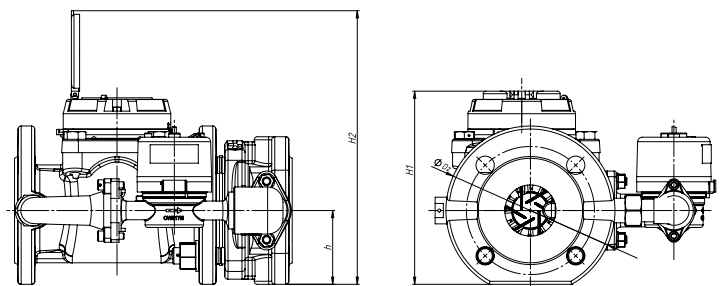

DN		50	65	80	100	150
H1	mm	188.5	199.5	220	230	351.5
H2	mm	267	278	298.5	308.5	430
h	mm	72	83	95	105	135
Dz	mm	165	185	200	220	285

Pressure loss chart

Pressure loss

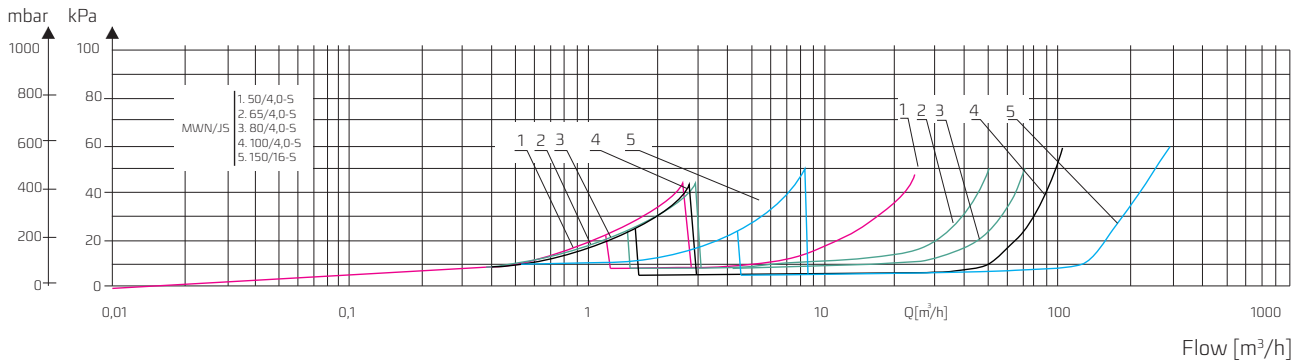

Typical error chart

Error [%]

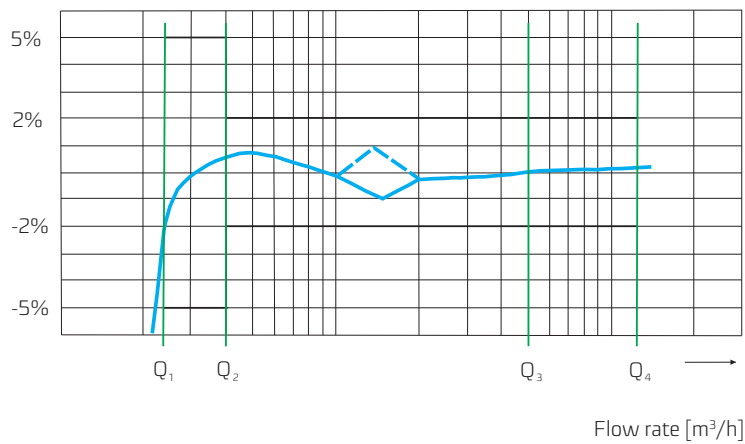

Remote indication relay & flow rate measurement for IP68/IP65; flow rate measurement

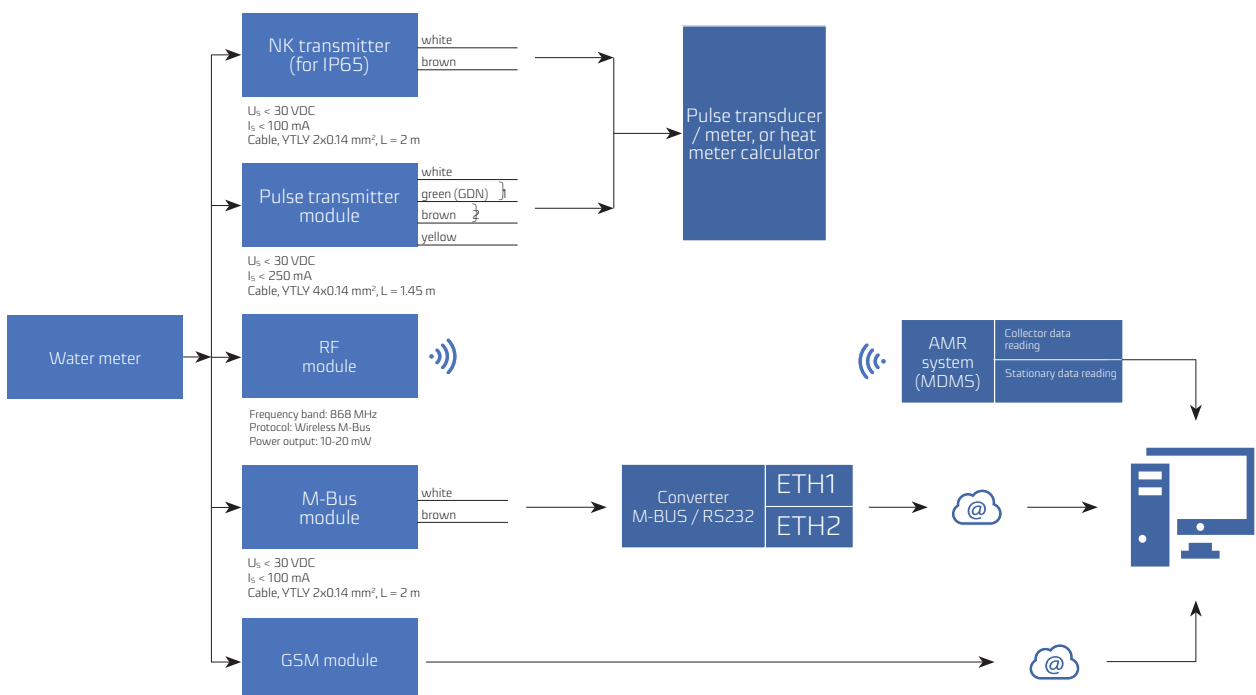

The data here is current on the date of issue.
The manufacturer has the right to modify and improve the products without prior notice.
This publication is indicative only and should not be construed as a commercial offer under the Polish Civil Code.



Apator Powogaz S.A.

Jaryszki 1c, 62-023 Żerniki, Poland

Office: sekretariat.powogaz@apator.com, tel. +48 61 84 18 101

Sales / Customer Service: tel.: +48 61 84 18 149

Customer Service Centre Support: handel.powogaz@apator.com

Export: export.powogaz@apator.com

Technical Support: support.powogaz@apator.com, tel. +48 61 8418 131, 134, 294

Warranty Claims: reklamacje.powogaz@apator.com

Контакти
044 391-21-13
067 659-43-44
050 307-15-15
boiler.ukr@gmail.com