

# MWN Nubis IP68/IP65

## MWN horizontal rotor axis propeller water meter (Woltman) DN40 to DN300



The MWN Nubis is a horizontal rotor axis propeller dry water meter of the Woltman design. The propeller axis is parallel to the piping centreline once installed. The Nubis water meters feature state-of-the-art design and processing solutions which provide a long operating life with resistance to strong external electromagnetic fields. The water meter is compatible with clip-on communication modules for automatic wired or wireless meter reading. The water meter has been designed and manufactured to the MID (Measuring Instruments Directive) and in compliance with EN14154, ISO4064 and OIML R49 for the maximum measurement range of R200.

## Application

The water meters are intended for metering in industrial supply systems of cold water operating at temperatures up to 50°C and hot water operating at temperatures up to 130°C at low pressure losses with relatively constant and high flow rates. The maximum admissible pressure (MAP) is 16 bar. The water meter design enables installation in horizontal piping with the counter pointing upward (H) or sideways (V) and in vertical pipelines with the counter pointing sideways (V). The rotary counter provides indications that are easily readable directly from the front face in different installation orientations. The water meters designed to IP68 are excellent for operation in difficult ambient conditions, and the standard version is compatible with universal induction communication modules which feature #UTIP (Universal TI Plug). The IP65 water meters are compatible with optical and induction communication modules.

### MWN-08 (IP68)

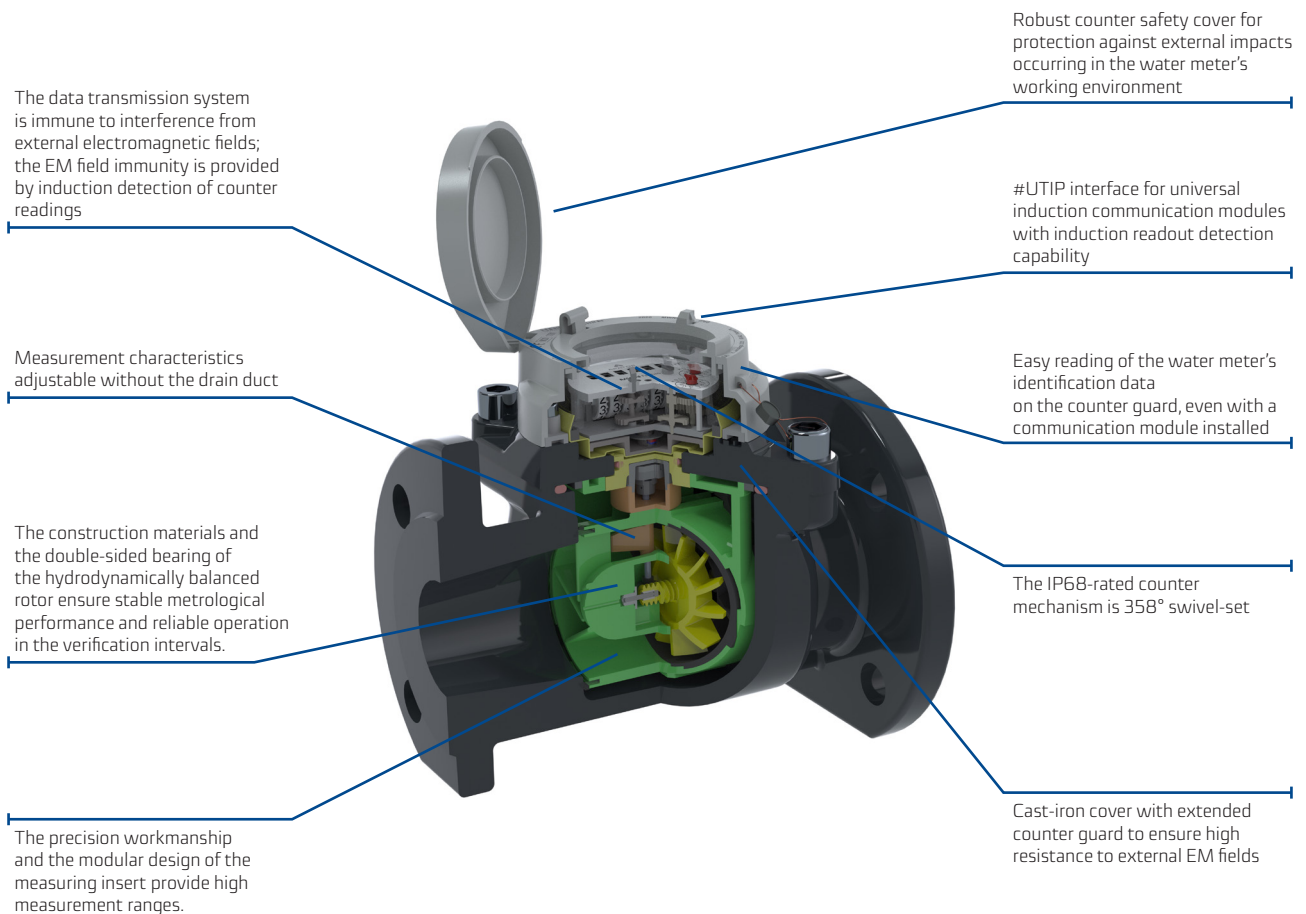

## MWN; MWN130 (IP65)

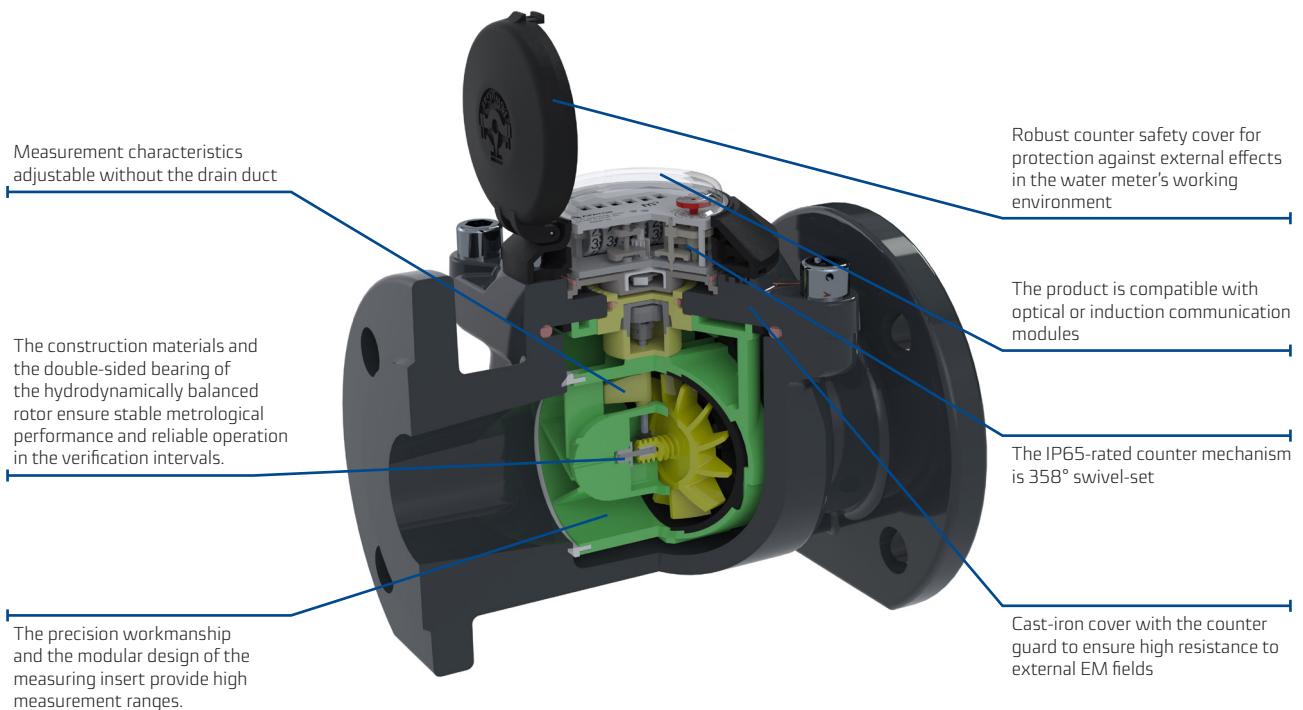

## Advantages

### Economic

- Excellent metrological parameters
- Remote meter reading via wired or wireless interfaces
- Low overall water meter weight
- Interchangeable, unified design of the measuring insert: compatible with several body sizes for optimum water meter installation management
- Possibility to install the water meter in many positions, without affecting the metrological parameters, allowing a more liberal design of new and existing water meter connections
- High anti-corrosive and damage resistance performance of the paint coat (made by epoxy powder coating)

### Convenience of use

- The standard water meter version is AMR (MDMS)-capable (automatic meter reading), while the IP68 version is provided with #UTIP for compatibility with universal induction communication modules
- Easy reading of indications and parameters by:
  - Any orientation of the counter mechanism within 0 to 358°
  - Hermetically sealed, non-fogging counter in the IP68 version
  - Location of the water meter parameter legend on the top surface of the counter cover in the IP68 version
- Remote wireless indication reading with a portable terminal or a stationary reading system
- Possibility of reading indications in a wired or wireless system, using:
  - NK and NO transmitters
  - optical modules (IR)
  - induction modules (Ti)

- Alarm output capability: the meter with a universal induction communication module is capable of remote indication of any removal of or damage to the module, disruption of operation, reverse flows, leakages, external EM fields, and more

## Reliability

- Tested and robust design
- Long operating life thanks to advanced materials:
  - with high resistance to wearing (in bearings and pivots)
  - with a surface texture which minimises flow resistance (on the rotor and the sealing disc)
  - with a revised construction and the applied hydrodynamically balanced rotor in the measurement chamber
- the counter mechanism is protected against mechanical damage
- the snap-locked counter cover of the IP68 version features the verification marking to eliminate traditional tamper seals

## Key features

- IP68 rated: capable of operation in extremely difficult ambient conditions (including full immersion in water) alone or with a communication module installed
- IP68 rated: highly aesthetic droplet-shaped design for the counter safety cover and guard
- EN14154-3 compliant resistance to external magnetic fields
- High performance and reliability with stable metrological parameters in the entire service life
- Low starting flow
- Wide metering range
- Electronic diagnostics of metrological parameters
- Modular design
- Removable measuring insert
- Magnetic coupling

## Regulatory and standards compliance

- Directive 2014/32/EC of the European Parliament and of the Council of 26 February 2014 on the harmonisation of the laws of the Member States relating to the making available on the market of measuring instruments
- Polish Act of 13/04/2016 on market surveillance and compliance assessment systems
- OIML R 49-1:2006 – Water meters intended for the metering of cold potable water and hot water. Part 1: Metrological and technical requirements
- OIML R 49-2:2004 – Water meters intended for the metering of cold potable water and hot water. Part 2: Test methods
- OIML R 49-2:2013 – Water meters intended for the metering of cold potable water and hot water. Part 2: Test methods
- OIML R 49-3:2013 – Water meters intended for the metering of cold potable water and hot water. Part 3: Test report format
- EN 14154-1:2005+A2:2011 – Water meters. Part 1: General requirements
- EN 14154-2:2005+A2:2011 – Water meters. Part 2: Installation and conditions of use
- EN 14154-3:2005+A2:2011 – Water meters. Part 3: Test methods and equipment
- EN ISO 4064-1:2017 – Water meters for cold potable water and hot water. Part 1: Metrological and technical requirements
- EN ISO 4064-2:2017 – Water meters for cold potable water and hot water. Part 2: Test methods
- EN ISO 4064-5:2017 – Water meters for cold potable water and hot water. Part 5: Installation requirements
- EU type test certificate – Cold water, no. SK08-MI001-SMU002
- PZH National Institute of Hygiene and WRAS certificates (all materials used in MWN water meters have Hy-



giene Certificates for use with potable water)

- Classification of environmental climate and mechanical conditions: Class B (ref. EN-ISO 4064-1:2014 (E))
- Classification of mechanical environmental conditions: Class M1, as per Directive 2014/32/EC of the European Parliament and of the Council of 26 February 2014
- Classification of electromagnetic environmental conditions: class E1 and E2, per EN-ISO 4064: 2014 and Directive 2014/32/EC of the European Parliament and of the Council of 26 February 2014

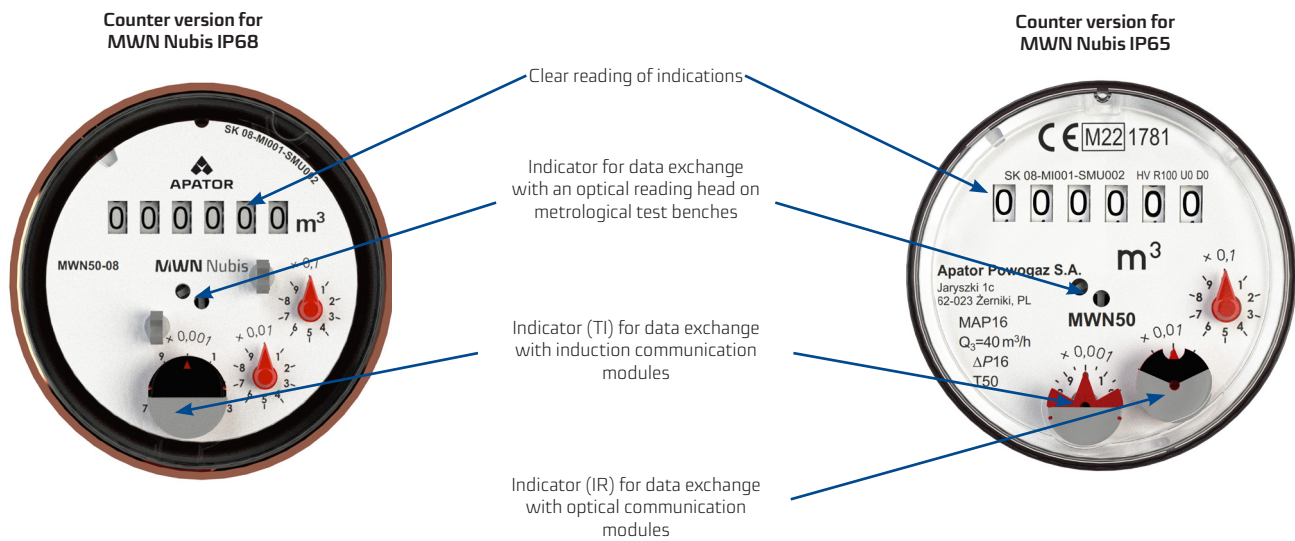

Table 1. Specifications

Parameter			MWN-08 (IP68); MWN (IP65)										
Nominal diameter	DN	mm	40	50	65	80	100	125	150	200	250	300	
Temperature class (operating temperature range)	T30 (0.1 to 30°C); T50 (0.1 to 50°C)		MWN-08 or MWN; MWN (version)-NKOP										
Permanent flow rate	Q <sub>3</sub>	m <sup>3</sup> /h	25	40	63	100	160	250	400	630	1000	1600	
Overload flow rate	Q <sub>4</sub>	m <sup>3</sup> /h	31.25	50	78.75	125	200	312.5	500	787.5	1250	2000	
Transitional flow rate	Q <sub>2</sub>	m <sup>3</sup> /h	0.4	0.64	0.806	1	1.28	2.5	3.2	8.064	16	20.48	25.6
Minimum flow rate	Q <sub>1</sub>	m <sup>3</sup> /h	0.25	0.4	0.504	0.625	0.8	1.563	2	5.04	10	12.8	16
Starting flow	–	m <sup>3</sup> /h	0.15	0.15	0.2	0.25	0.25	0.5	1.0	1.5	3	8	
Measurement range, R	Q <sub>3</sub> /Q <sub>1</sub>	–	100	100	125	160	200	160	200	125	100	125	100
Coefficient	Q <sub>2</sub> /Q <sub>1</sub>	–	1.6										
Maximum pressure loss	ΔP	kPa	ΔP10	ΔP16	ΔP40	ΔP10	ΔP25	ΔP25	ΔP25	ΔP16	ΔP10	ΔP10	
Temperature class (operating temperature range)	T130 (0.1 to 130°C)		MWN130 or MWN130 (version)-NKP										
Permanent flow rate	Q <sub>3</sub>	m <sup>3</sup> /h	25	25	40	63	100	160	250	400	1000	1600	
Overload flow rate	Q <sub>4</sub>	m <sup>3</sup> /h	31.25	31.25	50	78.75	125	200	312.5	500	1250	2000	
Transitional flow rate	Q <sub>2</sub>	m <sup>3</sup> /h	1	1	1.6	2.52	4	6.4	10	16	40	64	
Minimum flow rate	Q <sub>1</sub>	m <sup>3</sup> /h	0.625	0.625	1	1.575	2.5	4	6.25	10	25	40	
Starting flow	–	m <sup>3</sup> /h	0.25	0.25	0.3	0.35	0.6	1.1	2	4	8	15	
Measurement range, R	Q <sub>3</sub> /Q <sub>1</sub>	–	40	40	40	40	40	40	40	40	25	25	
Coefficient	Q <sub>2</sub> /Q <sub>1</sub>	–	1.6										
Maximum pressure loss	ΔP	kPa	ΔP10	ΔP16	ΔP40	ΔP10	ΔP25	ΔP25	ΔP25	ΔP16	ΔP10	ΔP10	
Connection ends: K – flanged*** G – threaded			K	K/G	K	K	K	K	K	K	K	K	
Flow profile sensitivity class	–	–	U0, D0										
Indicating range	–	m <sup>3</sup>	10 <sup>6</sup>					10 <sup>7</sup>					
Resolution of reading	–	m <sup>3</sup>	0.0005					0.005				0.05	
Maximum allowable pressure	P <sub>max</sub>	–	MAP16 = (16bar)										
Operating pressure range	–	bar	0.3 to 16										
Operating orientation	–	–	H, V										
Maximum permissible error range: (Q2 ≤ Q ≤ Q4)	ε	%	± 2 for 0.1°C ≤ T ≤ 30°C cold water ± 3 T > 30°C water										
Maximum permissible error range: (Q1 ≤ Q < Q2)	ε	%	±5										
Reed relay pulse transmitter NK (IP65 only)	–	dm <sup>3</sup> /pulse	100 (standard pulsing) 10 (available on request)							1000 (standard pulsing)			
										100 (available on request)		–	
Optoelectronic pulse transmitter NO (for IP65 T30 or T50 only)	–	dm <sup>3</sup> /pulse	1							10		105.2632	
			L	mm	200	200	200	225/200*	250	250	300	350	450
Dimensions	Height (IP68)	h	mm	65	72	83	95	105	120	135	160	193	230
		H	mm	179.5	186.5	197.5	218	228	255.5	350	375	422	489
		H1	mm	187.5	194.5	205.5	226	236	263.5	357	382	429	496
		H2	mm	264.5	271.5	282.5	303	313	340.5	434.1	459.1	506.1	573.1
	Height (IP65)	H	mm	168.6	175.6	186.6	207.1	217.1	244.6	338.9	363.9	410.9	477.9
		H1	mm	173.6	180.6	191.6	212.1	222.1	249.6	343.6	368.6	415.6	482.6
		H2	mm	236	243	254	274.5	284.5	312	406	431	478	545
		H3**	mm	283	290	301	347.5	358	385	580	604	650	720
	Dz	mm	150	165	185	200	220	250	285	340	400	460	
Weight	W/o transmitter		kg	7.9	9.9	10.6	13.3/13.8*	15.6	18.1	40.1	51.1	75.1	103.1
	w/NK or NO transmitter			8.3	10.3	11	13.7/14.2*	16	18.5	40.5	51.5	75.5	103.5

\* ISO 4064 standardised body length available on request.

\*\* Measuring insert removal clear height.

\*\*\* Connection flange bolt hole pattern:

- Standard: PN-EN 1092-2 (PN10), DIN 2532, DIN2501 (PN10), BS4504 (PN10)

- Special: PN-EN 1092-2 (PN16) (available on request)

- Extra: ANSI B16.5 Class 150 (DN40-300) (available on request)

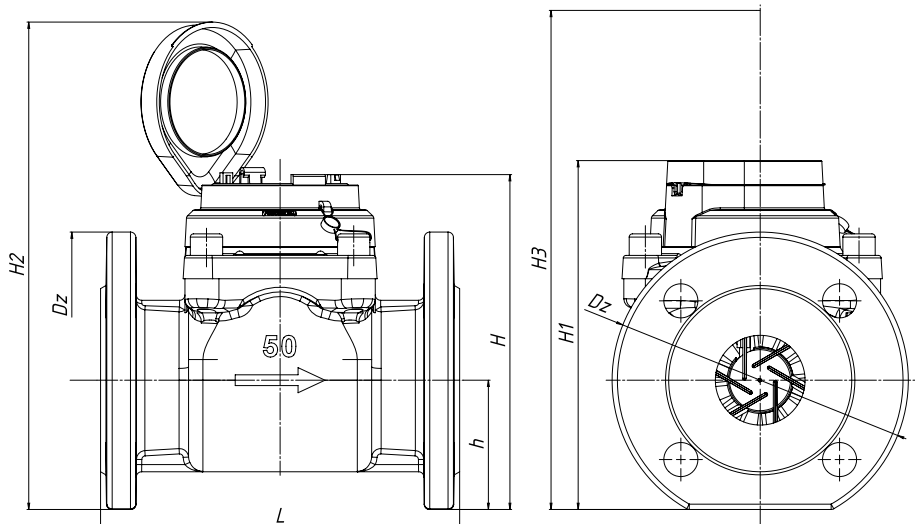

MWN version – 08 (IP68)

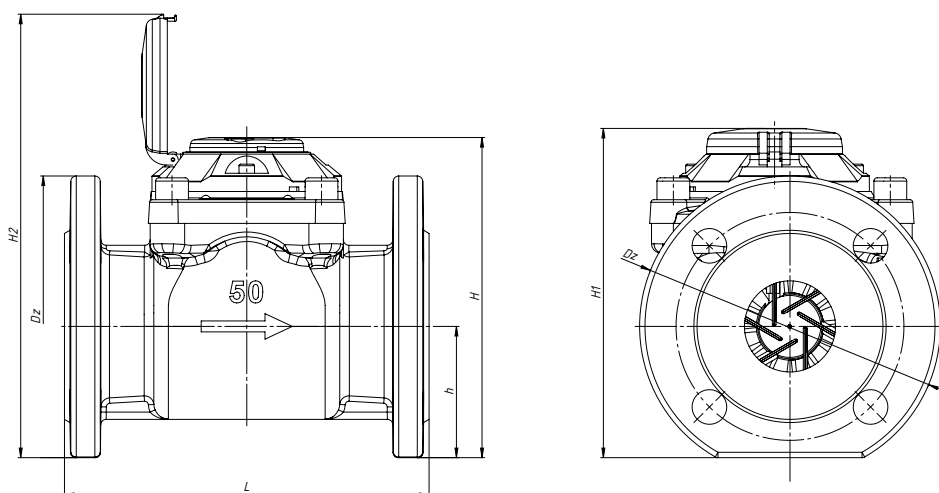

MWN version – (IP65)

**IP65-rated water meter, NKOP**

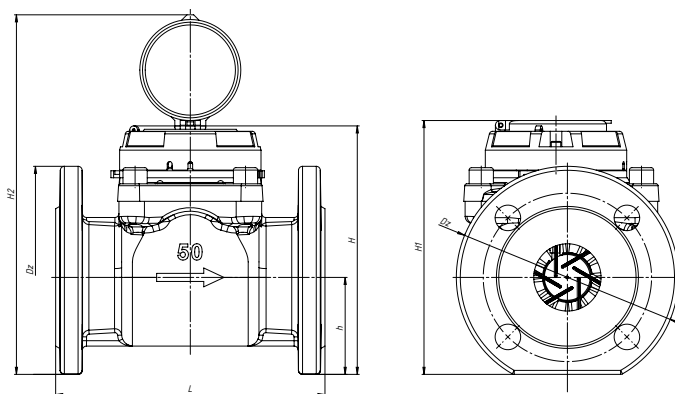

DN		40	50	65	80	100	125	150	200	250	300
H	mm	213.5	220.5	231.5	252	262	289.5	384	409	456	523
H1	mm	217.5	224.5	235.5	256	266	293.5	388	503	500	527
H2	mm	260	267	278	298.5	308.5	336	430.5	455.5	502.5	569.5

Example of MWN IP68 water meter compatibility with induction communication modules:

**IN-GSM induction module, #UTIP (Universal TI Plug)**

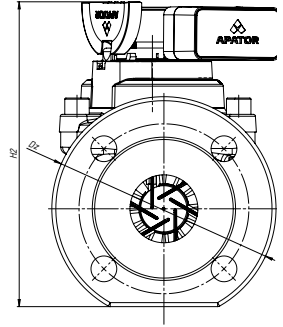
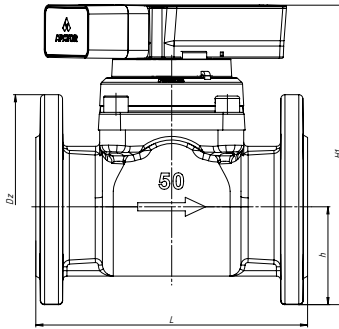

DN		40	50	65	80	100	125	150	200	250	300
H1	mm	213.5	220.5	231.5	252	262	289.5	384	409	456	523
H2	mm	217.5	224.5	235.5	256	266	293.5	388	503	500	527

**APT-WMBUS-NA-1 induction module, #UTIP (Universal TI Plug)**

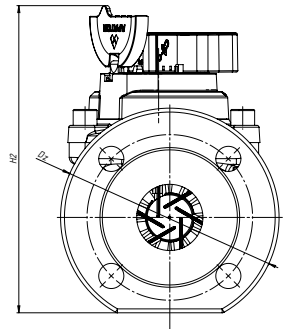
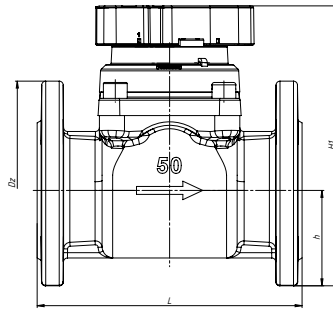

DN		40	50	65	80	100	125	150	200	250	300
H1	mm	204.1	211.1	222.1	242.6	252.6	280.1	374.6	399.6	446.6	513.6
H2	mm	225.1	232.1	243.1	263.1	273.6	301.1	395.6	420.6	467.6	534.6

**IN-PULSE induction module**

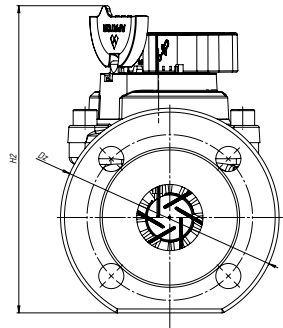
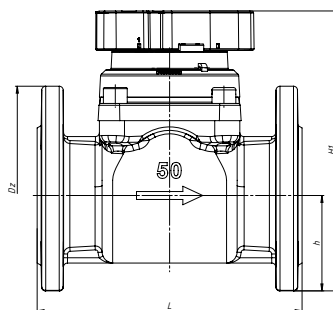

DN		40	50	65	80	100	125	150	200	250	300
H1	mm	204.1	211.1	222.1	242.6	252.6	280.1	374.6	399.6	446.6	513.6
H2	mm	225.1	232.1	243.1	263.1	273.6	301.1	395.6	420.6	467.6	534.6

Example of MWN IP65 water meter compatibility with induction communication modules:

### IN-GSM induction module

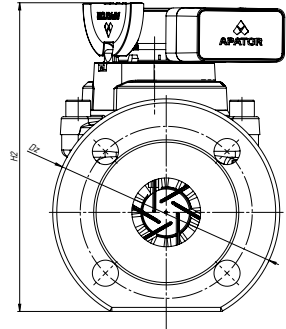
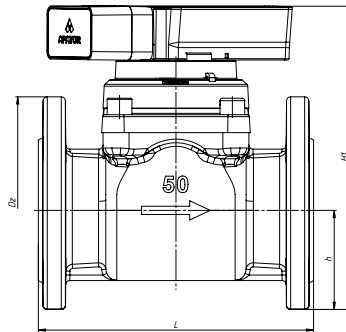

DN		40	50	65	80	100	125	150	200	250	300
H1	mm	213	220	231	251.5	261.5	289	383.5	408.5	455.5	522.5
H2	mm	217.9	224.9	235.9	256.4	266.4	293.9	388.4	413.4	460.4	527.4

### APT-WMBUS-NA-1 induction module

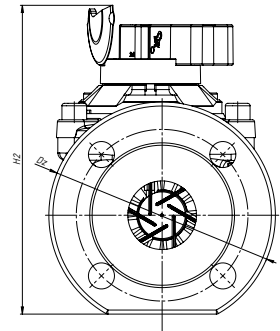
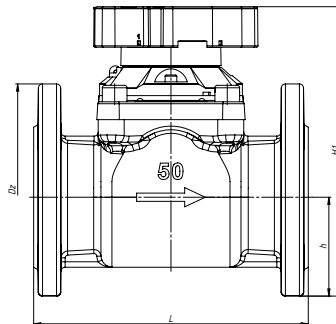

DN		40	50	65	80	100	125	150	200	250	300
H1	mm	203.8	210.8	221.8	242.3	252.3	279.8	374.3	399.3	446.3	513.3
H2	mm	217.9	224.9	235.9	256.4	266.4	293.9	388.4	413.4	460.4	527.4

### IN-PULSE induction module

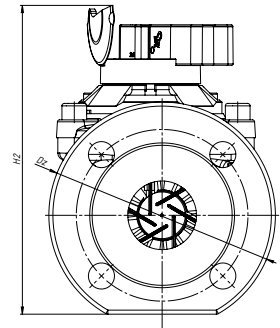
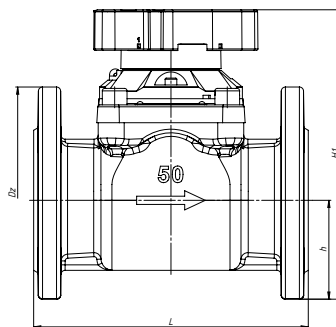

DN		40	50	65	80	100	125	150	200	250	300
H1	mm	203.8	210.8	221.8	242.3	252.3	279.8	374.3	399.3	446.3	513.3
H2	mm	217.9	224.9	235.9	256.4	266.4	293.9	388.4	413.4	460.4	527.4

## Pressure loss chart

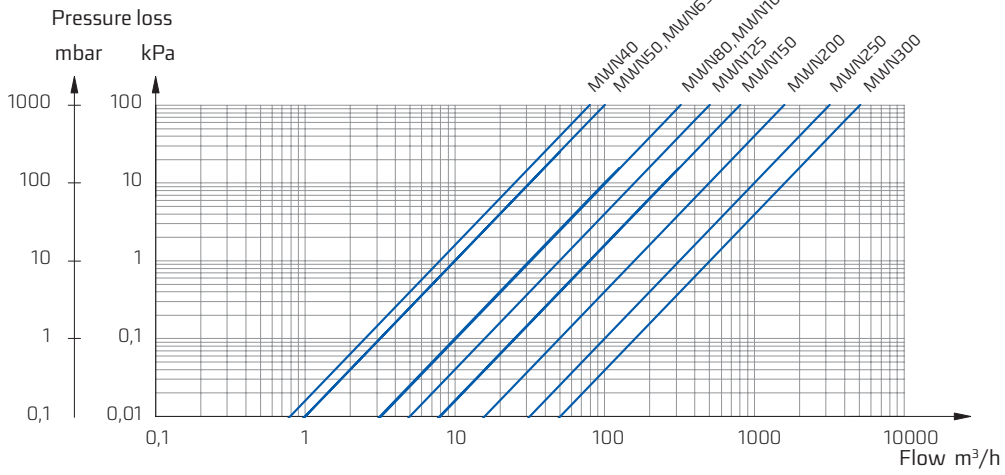

## Typical error chart

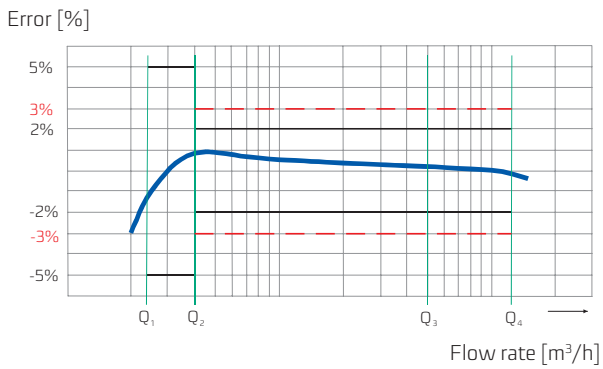

The data shown here is current on the date of issue.  
The manufacturer has the right to modify and improve the products without notice.  
This publication is indicative only and should not be construed as a commercial offer under the Polish Civil Code.



**Apator Powogaz S.A.**

Jaryszki 1c, 62-023 Żerniki, Poland

e-mail: [handel.powogaz@apator.com](mailto:handel.powogaz@apator.com)

Office: tel. +48 61 8418 101

Sales: tel. +48 61 8418 ext. 133 / 136 / 138 / 148

Exports: tel. +48 61 8418 139

[www.apator.com](http://www.apator.com)

Контакти  
044 391-21-13  
067 659-43-44  
050 307-15-15  
[boiler.ukr@gmail.com](mailto:boiler.ukr@gmail.com)

2026.005.EN

<https://boiler.ua/ua/>