

Справ. №

Подп. и дата  
Инв. № дубл.  
Взам. инв. №

Подп. и дата  
Инв. № подл.

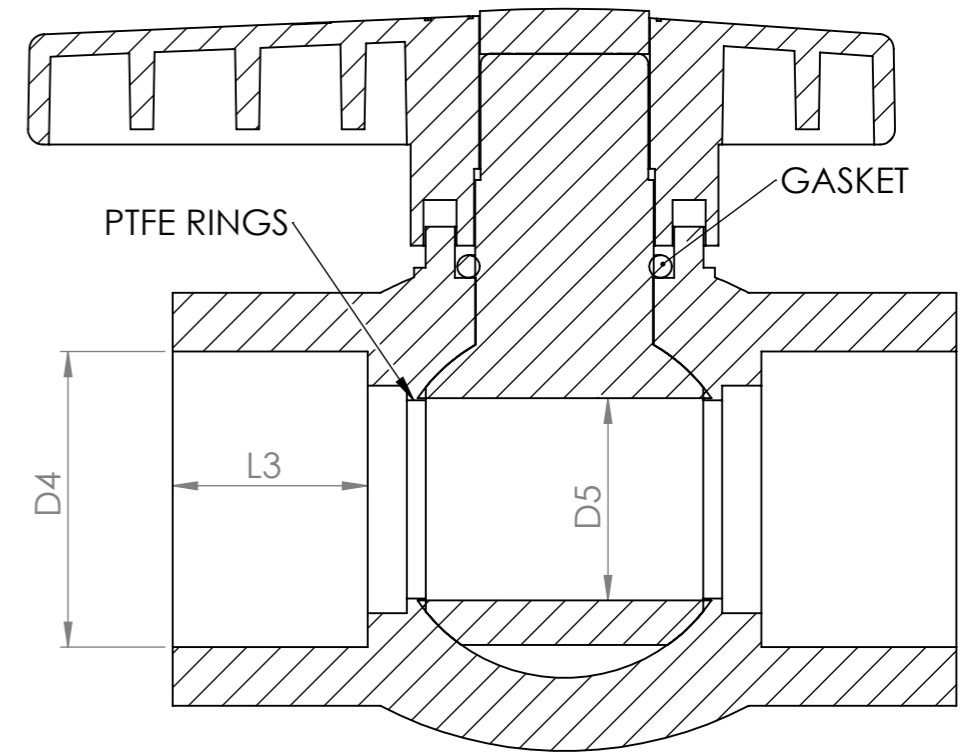
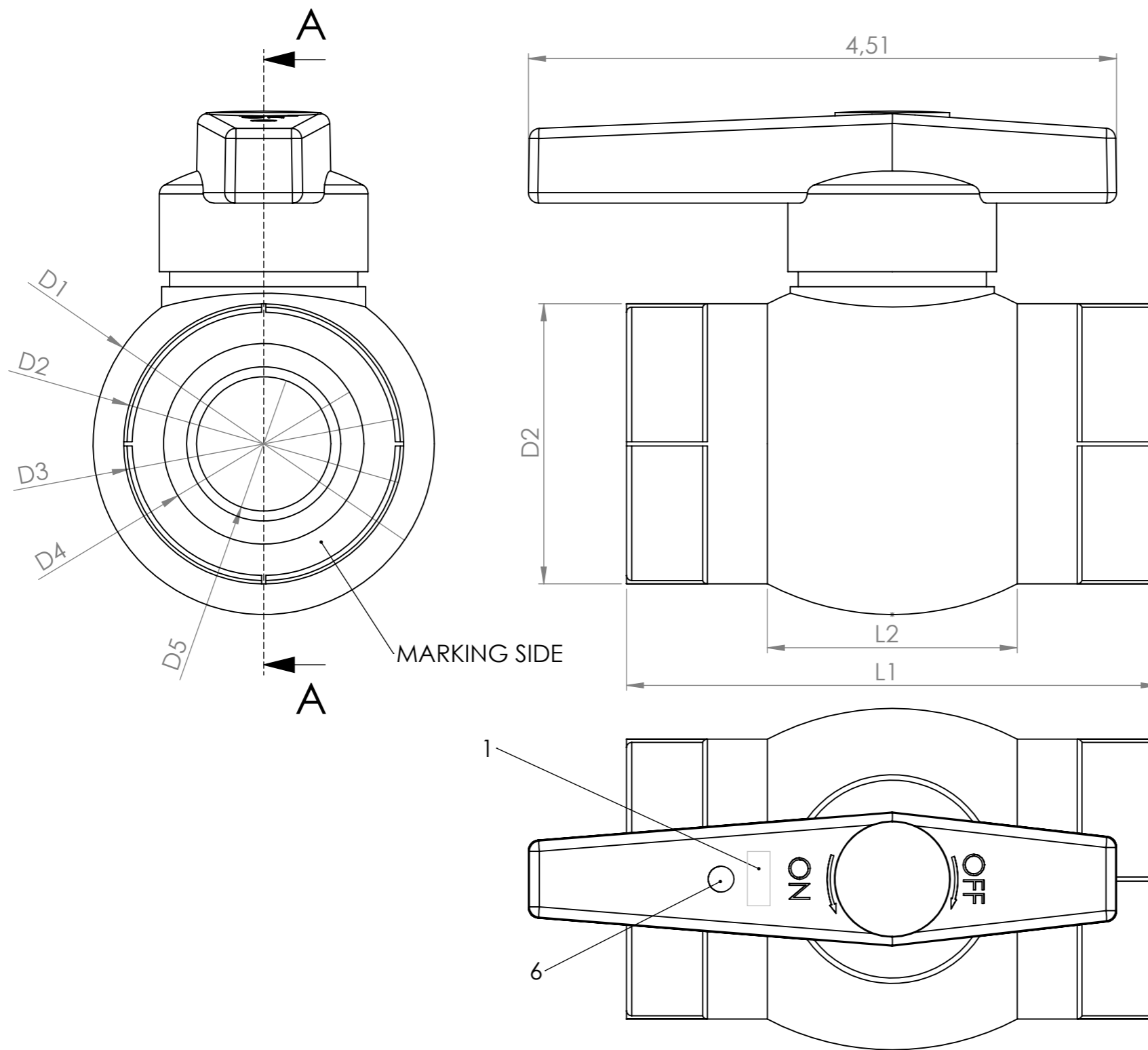

SECTION A-A

SCALE 1:1

Marking on plastic body :

1. FADO logo
2. Material type: PP-R
3. Size
4. Pressure:PN25
5. Cavity number
6. Date of production

Forbidden any scratches, burrs, shrinkage, injection gate on surface.

Forbidden any air cavity in plastic volume.

All not marked tolerance according to DIN ISO 20457

Part should conform EN ISO 15874-3

ART	D1	D2	D3	D4	D5	L1	L2	L3	WEIGHT FULL	SIZE
PKG21	39.04	29.2	28.42	19.2	14	76.6	38.4	16.4	58	20
PKG22	46.4	35.8	35.3	24.1	19.8	79	41.15	18.15	82	25
PKG23	56.11	44.2	43.6	31	22	88.3	43.66	20.4	129	32
PKG24	66.6	54.4	53.15	39	26.4	104.1	48.65	25.75	212.8	40

				PKG2_GEN COLD WATER BALL VALVE FADO		
				Лит.	Масса	Масштаб
Изм.	Лист	№ докум.	Подп.	Дата		
Разраб.						
Пров.						
Т. контр.						
				PKG2_GEN		
				Лист	Листов	
Н. контр.						
Утв.						