

Справ. №

Подп. и дата

Взам. инв. №  
Инв. № дубл.  
Подп. и дата  
Инв. № подл.

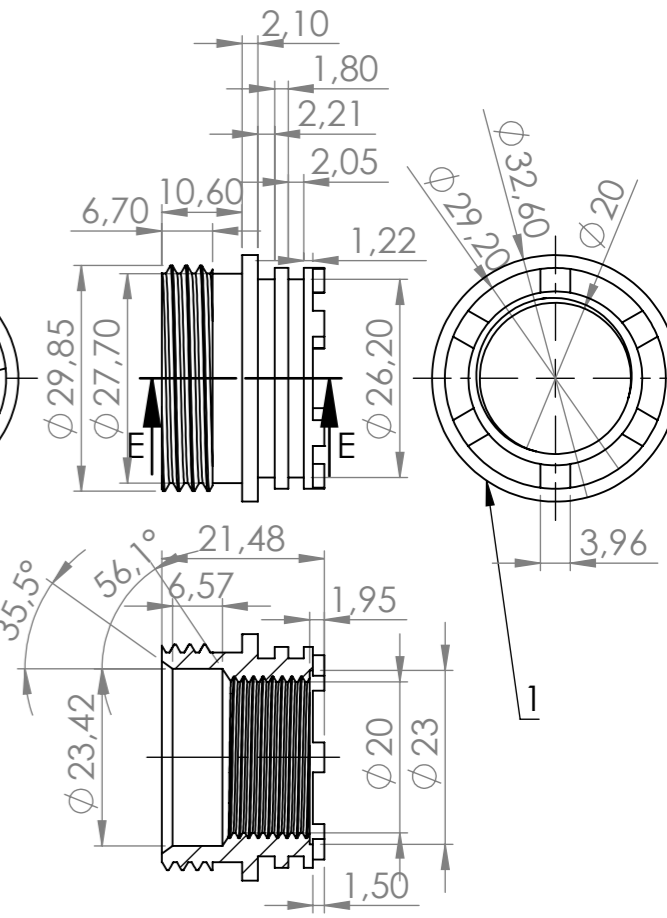
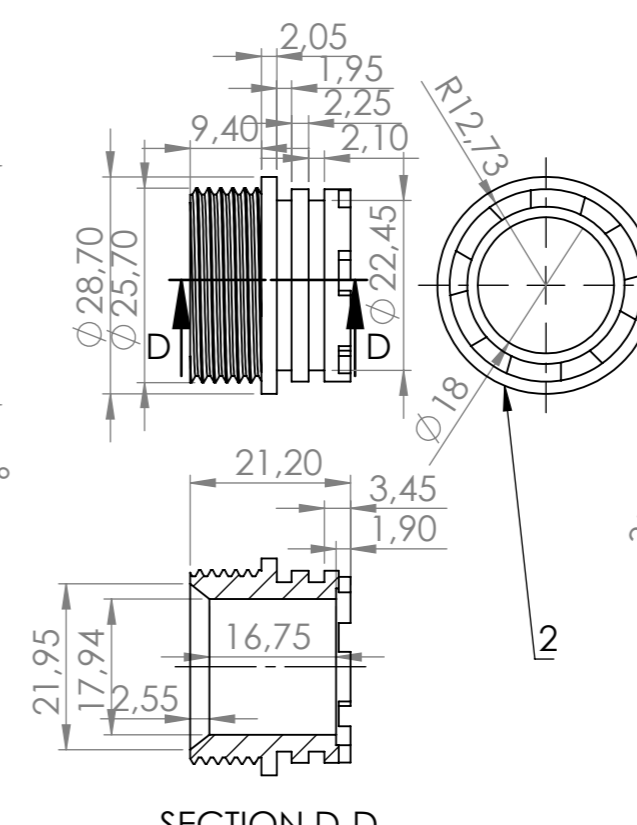
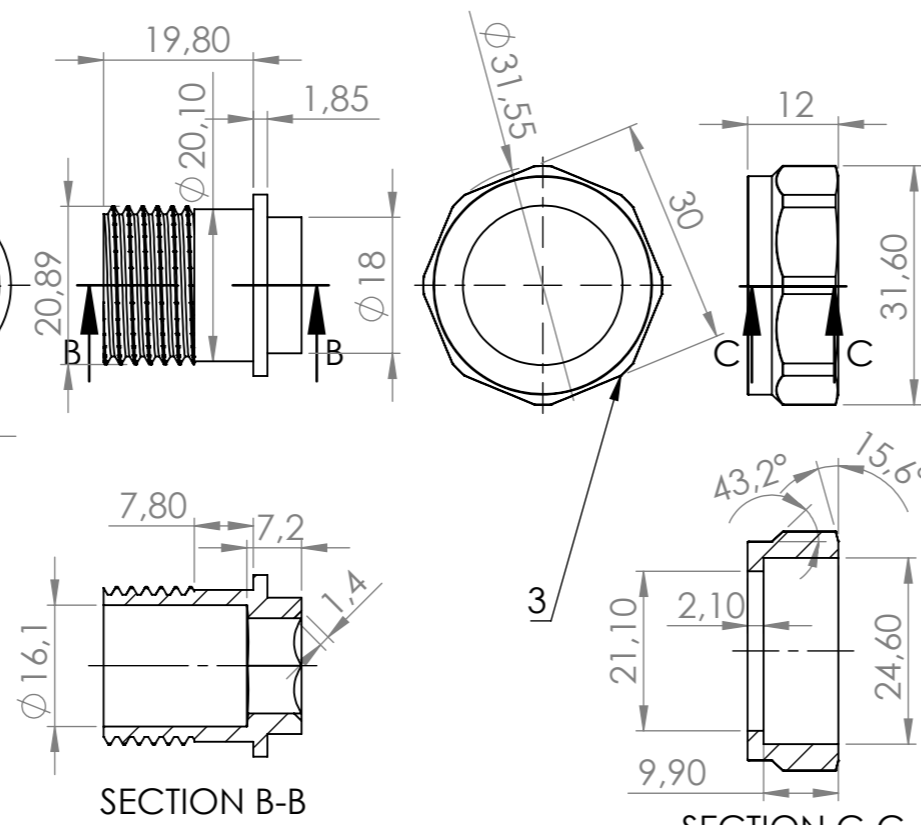
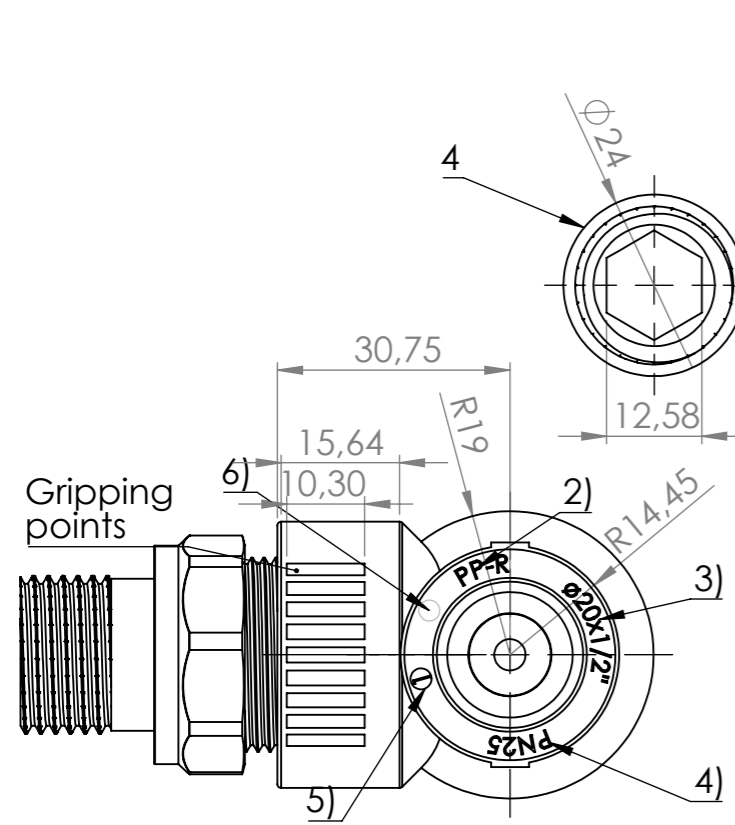
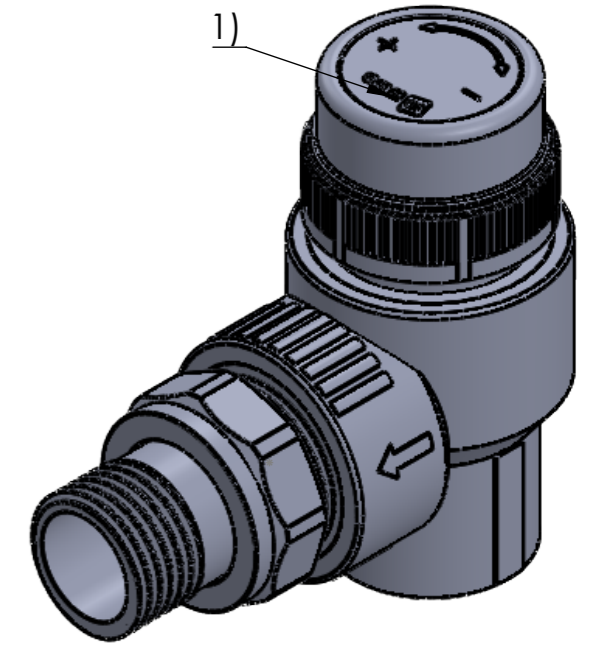
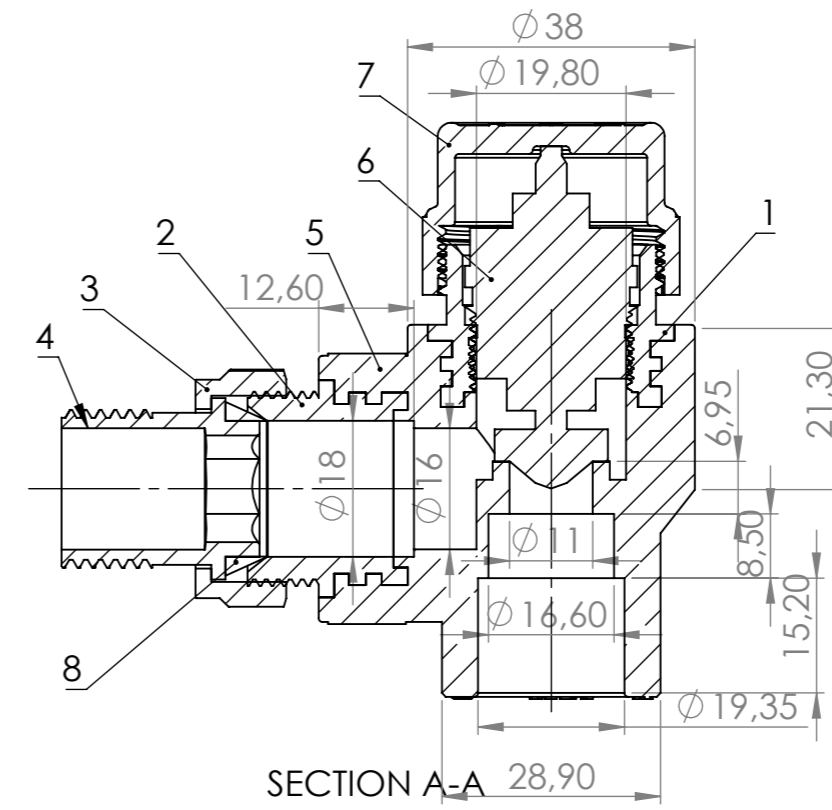
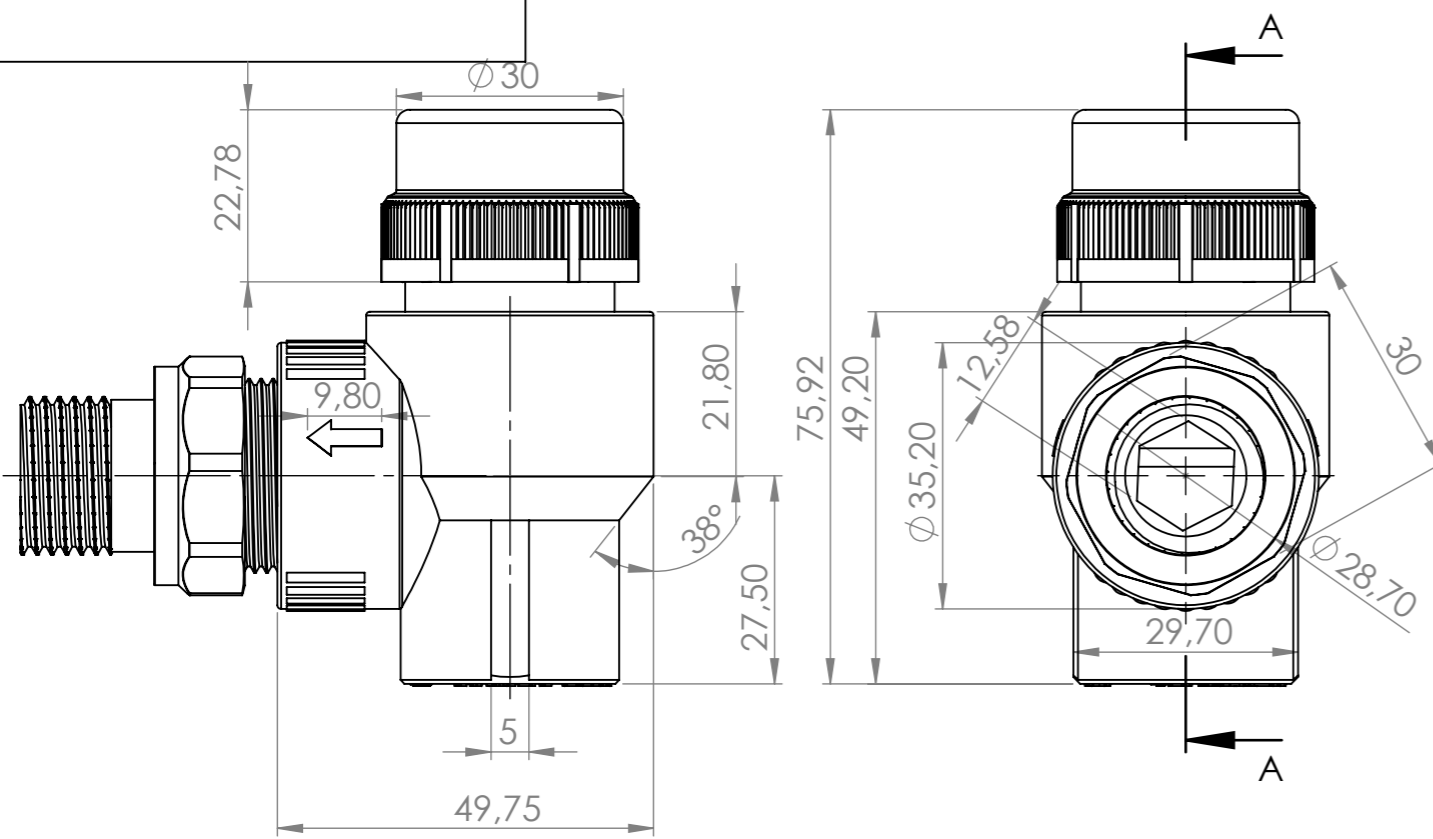

#	ART	NAME	WEIGHT
1	3PKT02	INSERT M30	42.7
2	1_2INPKT02	INSERT 1/2	37
3	1_2UNPKT02	UNION 1/2	26.6
4	1_NPKT02	NUT 1/2	22.7
5	PLPKT02	PLASTIC BODY	30.9
6	VPKT02	VALVE	59.2
7	CPKT02	CAP	6.9
8	GPKT02	GASKET	0.6

SECTION B-B

Annotations

1. FADO logo
2. Material type: PP-R
3. Size: 20x1/2"
4. Nominal pressure PN25
5. Cavity number
6. Date of production

Forbidden any scratches, burrs, shrinkage, injection gate on surface. Forbidden any air cavity in plastic volume. All not marked tolerance according to Part should conform EN ISO 15874-3

Изм.	Лист	№ докум.	Подп.	Дата

PKT02 ASM STOP VALVE FOR RADIATOR

PKT02

Лит.	Масса	Масштаб
	226.6	1:1
Лист 1	Листов 1	

